

SW HDMI Series

HDMI Switchers



Safety Instructions

Safety Instructions • English

WARNING: This symbol, , when used on the product, is intended to alert the user of the presence of uninsulated dangerous voltage within the product's enclosure that may present a risk of electric shock.

ATTENTION: This symbol, , when used on the product, is intended to alert the user of important operating and maintenance (servicing) instructions in the literature provided with the equipment.

For information on safety guidelines, regulatory compliances, EMI/EMF compatibility, accessibility, and related topics, see the Extron Safety and Regulatory Compliance Guide, part number 68-290-01, on the Extron website, www.extron.com.

Instructions de sécurité • Français

AVERTISSEMENT: Ce pictogramme, , lorsqu'il est utilisé sur le produit, signale à l'utilisateur la présence à l'intérieur du boîtier du produit d'une tension électrique dangereuse susceptible de provoquer un choc électrique.

ATTENTION: Ce pictogramme, , lorsqu'il est utilisé sur le produit, signale à l'utilisateur des instructions d'utilisation ou de maintenance importantes qui se trouvent dans la documentation fournie avec le matériel.

Pour en savoir plus sur les règles de sécurité, la conformité à la réglementation, la compatibilité EMI/EMF, l'accessibilité, et autres sujets connexes, lisez les informations de sécurité et de conformité Extron, réf. 68-290-01, sur le site Extron, www.extron.fr.

Sicherheitsanweisungen • Deutsch

WARNUNG: Dieses Symbol , auf dem Produkt soll den Benutzer darauf aufmerksam machen, dass im Inneren des Gehäuses dieses Produktes gefährliche Spannungen herrschen, die nicht isoliert sind und die einen elektrischen Schlag verursachen können.

VORSICHT: Dieses Symbol , auf dem Produkt soll dem Benutzer in der im Lieferumfang enthaltenen Dokumentation besonders wichtige Hinweise zur Bedienung und Wartung (Instandhaltung) geben.

Weitere Informationen über die Sicherheitsrichtlinien, Produkthandhabung, EMI/EMF-Kompatibilität, Zugänglichkeit und verwandte Themen finden Sie in den Extron-Richtlinien für Sicherheit und Handhabung (Artikelnummer 68-290-01) auf der Extron-Website, www.extron.de.

Instrucciones de seguridad • Español

ADVERTENCIA: Este símbolo, , cuando se utiliza en el producto, avisa al usuario de la presencia de voltaje peligroso sin aislar dentro del producto, lo que puede representar un riesgo de descarga eléctrica.

ATENCIÓN: Este símbolo, , cuando se utiliza en el producto, avisa al usuario de la presencia de importantes instrucciones de uso y mantenimiento recogidas en la documentación proporcionada con el equipo.

Para obtener información sobre directrices de seguridad, cumplimiento de normativas, compatibilidad electromagnética, accesibilidad y temas relacionados, consulte la Guía de cumplimiento de normativas y seguridad de Extron, referencia 68-290-01, en el sitio Web de Extron, www.extron.es.

Chinese Simplified (简体中文)

警告:  产品上的这个标志意在警告用户该产品机壳内有暴露的危险电压, 有触电危险。

注意:  产品上的这个标志意在提示用户设备随附的用户手册中有重要的操作和维护(维修)说明。

关于我们产品的安全指南、遵循的规范、EMI/EMF 的兼容性、无障碍使用的特性等相关内容, 敬请访问 Extron 网站 www.extron.cn, 参见 Extron 安全规范指南, 产品编号 68-290-01。

Chinese Traditional (繁體中文)

警告:  若產品上使用此符號, 是為了提醒使用者, 產品機殼內存在著可能會導致觸電之風險的未絕緣危險電壓。

注意:  若產品上使用此符號, 是為了提醒使用者。

有關安全性指導方針、法規遵守、EMI/EMF 相容性、存取範圍和相關主題的詳細資訊, 請瀏覽 Extron 網站: www.extron.cn, 然後參閱《Extron 安全性與法規遵守手冊》, 準則編號 68-290-01。

Japanese

警告: この記号  が製品上に表示されている場合は、筐体内に絶縁されていない高電圧が流れ、感電の危険があることを示しています。

注意: この記号  が製品上に表示されている場合は、本機の取扱説明書に記載されている重要な操作と保守(整備)の指示についてユーザーの注意を喚起するものです。

安全上のご注意、法規厳守、EMI/EMF適合性、その他の関連項目については、エクストロンのウェブサイト www.extron.jp より『Extron Safety and Regulatory Compliance Guide』(P/N 68-290-01) をご覧ください。

Korean

경고: 이 기호  가 제품에 사용될 경우, 제품의 인클로저 내에 있는 접지되지 않은 위험한 전류로 인해 사용자가 감전될 위험이 있음을 경고합니다.

주의: 이 기호  가 제품에 사용될 경우, 장비와 함께 제공된 책자에 나와 있는 주요 운영 및 유지보수(정비) 지침을 경고합니다.

안전 가이드라인, 규제 준수, EMI/EMF 호환성, 접근성, 그리고 관련 항목에 대한 자세한 내용은 Extron 웹 사이트(www.extron.co.kr)의 Extron 안전 및 규제 준수 안내서, 68-290-01 조항을 참조하십시오.

FCC Class A Notice

This equipment has been tested and found to comply with the limits for a Class A digital device, pursuant to part 15 of the FCC rules. The Class A limits provide reasonable protection against harmful interference when the equipment is operated in a commercial environment. This equipment generates, uses, and can radiate radio frequency energy and, if not installed and used in accordance with the instruction manual, may cause harmful interference to radio communications. Operation of this equipment in a residential area is likely to cause interference; the user must correct the interference at his own expense.

Copyright

© 2013 Extron Electronics. All rights reserved.

Trademarks

All trademarks mentioned in this guide are the properties of their respective owners.

The following registered trademarks[®], registered service marksSM, and trademarksTM are the property of RGB Systems, Inc. or Extron Electronics:

Registered Trademarks [®]
AVTrac, Cable Cubby, CrossPoint, eBUS, EDID Manager, EDID Minder, Extron, Flat Field, GlobalViewer, Hideaway, Inline, IP Intercom, IP Link, Key Minder, LockIt, MediaLink, PlenumVault, PoleVault, PowerCage, PURE3, Quantum, SoundField, SpeedMount, SpeedSwitch, System Integrator, TeamWork, TouchLink, V-Lock, VersaTools, VN-Matrix, VoiceLift, WallVault, WindoWall
Registered Service MarkSM : S3 Service Support Solutions
Trademarks TM
AAP, AFL (Accu-Rate Frame Lock), ADSP (Advanced Digital Sync Processing), AIS (Advanced Instruction Set), Auto-Image, CDRS (Class D Ripple Suppression), DDSP (Digital Display Sync Processing), DMI (Dynamic Motion Interpolation), Driver Configurator, DSP Configurator, DSVP (Digital Sync Validation Processing), FastBite, FOXBOX, IP Intercom HelpDesk, MAAP, MicroDigital, ProDSP, QS-FPC (QuickSwitch Front Panel Controller), Scope-Trigger, SIS, Simple Instruction Set, Skew-Free, SpeedNav, Triple-Action Switching, XTP, XTP Systems, XTRA, ZipCaddy, ZipClip

Conventions Used in this Guide

Notifications

The following notifications are used in this guide:

CAUTION: A caution indicates a situation that **may** result in minor injury.

ATTENTION: Attention indicates a situation that may damage or destroy the product or associated equipment.

NOTE: A note draws attention to important information.

Software Commands

Commands are written in the fonts shown here:

```
^ARMerge Scene, ,Op1 scene 1,1 ^B 51 ^W ^C  
[Ø1] RØØØ4 ØØ3ØØ ØØ4ØØ ØØ8ØØ ØØ6ØØ [Ø2] 35 [17] [Ø3]
```

```
Esc X1 * X17 * X20 * X23 * X21 CE ←
```

NOTE: For commands and examples of computer or device responses mentioned in this guide, the character “Ø” is used for the number zero and “O” is the capital letter “o.”

Computer responses and directory paths that do not have variables are written in the font shown here:

```
Reply from 2Ø8.132.18Ø.48: bytes=32 times=2ms TTL=32  
C:\Program Files\Extron
```

Variables are written in slanted form as shown here:

```
ping xxx.xxx.xxx.xxx -t  
SOH R Data STX Command ETB ETX
```

Selectable items, such as menu names, menu options, buttons, tabs, and field names are written in the font shown here:

```
From the File menu, select New.  
Click the OK button.
```

Specifications Availability

Product specifications are available on the Extron website, www.extron.com.

Contents

Introduction 1

About this Guide.....	1
About the SW HDMI Series Switchers	1
Features	1
Application Diagrams.....	3

Installation 4

Installation Overview	4
Rear Panel Features	5
Wiring the Power Connector — SW2 and SW4 HDMI Only (Optional).....	7
Wiring for RS-232 Control	8
Connecting to the USB Port	9
Enabling Auto-input Switching	10
Wiring for Input Selection by Contact Closure.....	11
Wiring the Tally Out Port to Indicate the Input Selection	12

Operation 13

Front Panel Features.....	13
Operations.....	15
Powering on the Switcher.....	15
Selecting an Input.....	15
Resetting	16
Using the Optional IR 102 Remote Control	16
Locking and Unlocking the Front Panel (Executive Mode)	17
EDID Modes	17

Remote Communication and Control 21

Using Simple Instruction Set (SIS)	
Commands	21
Host-to-switcher Communications	21
Switcher-initiated Messages	21
Error Responses.....	22
Using the Command and Response Table	22
Symbol Definitions	23
Command and Response Table for SIS Commands	24
Updating Firmware Using Firmware Loader	27
Downloading and Installing Firmware Loader.....	27
Downloading the SW HDMI Firmware	27
Loading the Firmware to the Switcher.....	28

Reference Information 33

Mounting the SW HDMI.....	33
Tabletop Use	33
Rack Mounting	33
Furniture Mounting—SW2 and SW4 HDMI Only.....	33

Introduction

This section gives an overview of the SW HDMI Series switchers. Topics include:

- **About this Guide**
- **About the SW HDMI Series Switchers**
- **Features**
- **Application Diagrams**

About this Guide

This guide describes the Extron SW HDMI Series switchers and discusses how to install, configure, and operate them.

In this guide, the term “SW HDMI Series” refers to the SW2, SW4, SW6, and SW8 HDMI switchers. “Switcher” and “SW HDMI” are used to refer to any single unit.

About the SW HDMI Series Switchers

The SW HDMI Series are two, four, six, and eight input, one output, High-definition Multimedia Interface (HDMI) switchers. They allow multiple HDMI input signals, including digital video, 3D signals, and embedded multi-channel digital audio to be switched to one compatible output display. These switchers support all standard single-link HDMI (up to 2.25 Gbps) and Digital Video Interface (DVI) 1.0 signal formats. They are compatible at 60 Hz with all HDTV resolutions up to 1080p and PC resolutions up to 2048x1080, with 12-bit color, and are fully compliant with High-bandwidth Digital Content Protection (HDCP).

The SW HDMI switchers can be controlled via the front panel, the RS-232 interface, USB, contact closure, or the optional IR 102 Remote Control. You can select inputs by pressing the front panel buttons, pressing buttons on the IR 102, enabling auto-input switching, attaching a jumper or a contact closure device to the Contact port, or entering Simple Instruction Set (SIS) commands via RS-232 or USB.

Features

- **HDCP authentication** — The SW HDMI switchers check the sources and the display individually for HDCP compliance. HDCP LEDs for each input and the output indicate successful HDCP authentication.
- **Auto-input switching** — The SW HDMI Series can be configured to automatically switch to the highest-numbered active input when the switcher detects a signal.
- **Signal detection LEDs** — Each input and the output are represented by front panel LEDs, which light if a signal is present for the input or output and there is activity on the Transition Minimized Differential Signaling (TMDS) lines.
- **Contact closure** — The Contact port enables inputs to be selected by contact closure, with or without a contact closure device.
- **Tally output port** — Can be used in conjunction with the Contact port to indicate the selected switcher input.

- **Rack and furniture mounting** — The SW HDMI Series can be mounted on a rack shelf or under a desk or podium with an optional mounting kit.
- **Remote configuration and control** — The switcher can be configured via an RS-232 or USB connection via SIS commands (see [Remote Communication and Control](#) beginning on page 21).
- **EDID Minder** — A proprietary EDID (Extended Display Identification Data) management process from Extron, the EDID Minder manages the EDID between a digital display device and one or more input sources. By maintaining continuous EDID communication with all sources, EDID Minder ensures that digital sources power up properly and maintain their video output, whether or not they are actively connected to the digital display device.
- **EDID modes** — Either of the following EDID modes can be selected using SIS commands:
 - **Automatic**, in which the SW HDMI reads the EDID data when a display is connected and stores the data in memory (default mode)
 - **User-assigned**, in which you can assign one of 48 factory-provided EDID files to each input. Four undefined memory slots are also provided, to which you can save the EDID of connected displays as additional EDID files. The assigned EDID does not change if a different display device is connected. This mode is useful for troubleshooting purposes.

Each time power is applied to the output device or when the display is replaced, the SW HDMI either reads the EDID information from the display or reloads the user-assigned EDID information. It then writes the information to non-volatile memory on the inputs. The input devices can read this information as they reboot (see [EDID Modes](#) on page 17 for more information).

- **Output compatibility correction** — The SW HDMI monitors the EDID on the connected output device to ensure that it is compatible with the currently selected input signal. The following corrections are made to the signal as necessary each time an input is selected:
 - **Interface format:** If the connected output device is DVI and the selected source is HDMI, the signal is reformatted for DVI. If the output device is an HDMI device, no reformatting is necessary because HDMI is backwards compatible with DVI.
 - **Video color bit depth:** If the connected output device does not support the color bit depth of the selected source signal, it is truncated to the next level down that is supported. For example, 12-bit > 10-bit > 8-bit. Bit depth truncation can be forced via SIS commands to always downgrade to 8-bit depth, disabling deep color.
- **IR remote control (optional)** — The hand-held IR 102 Remote Control can control the SW HDMI via infrared signals that it sends to the switcher from a distance of up to 30 feet (9 m).
- **Front panel security lockout (executive mode)** — To prevent unauthorized access to the switchers, the front panel controls can be locked via the front panel buttons or SIS commands (RS-232, USB, and IR control remain available).
- **Input cable equalization** — Automatic input cable equalization compensates for signal loss when long cable assemblies are used.
- **Power supply** —
 - **SW2 and SW4 HDMI:** An energy-efficient, external 12 VDC, 1 A universal power supply with a 2-pole captive screw connector accepts 100 to 240 VAC.
 - **SW6 and SW8 HDMI:** An 50-60 Hz, internal universal power supply with a standard IEC connector accepts 100 to 240 VAC.

Application Diagrams

The following diagrams show examples of how SW HDMI Series switchers can be connected.

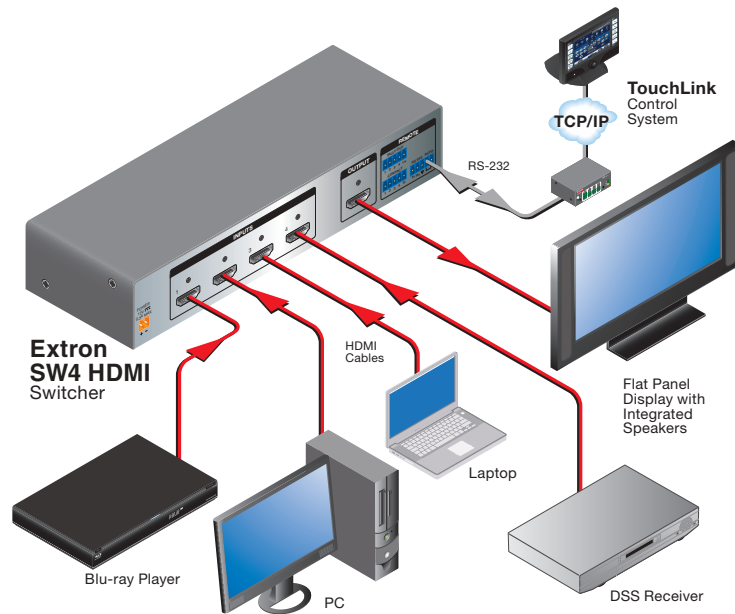

Figure 1. Application Diagram for an SW4 HDMI Switcher

NOTE: HDCP compliant sources require HDCP compliant displays (see the user manual of the source or display device for information on its HDCP compliance).

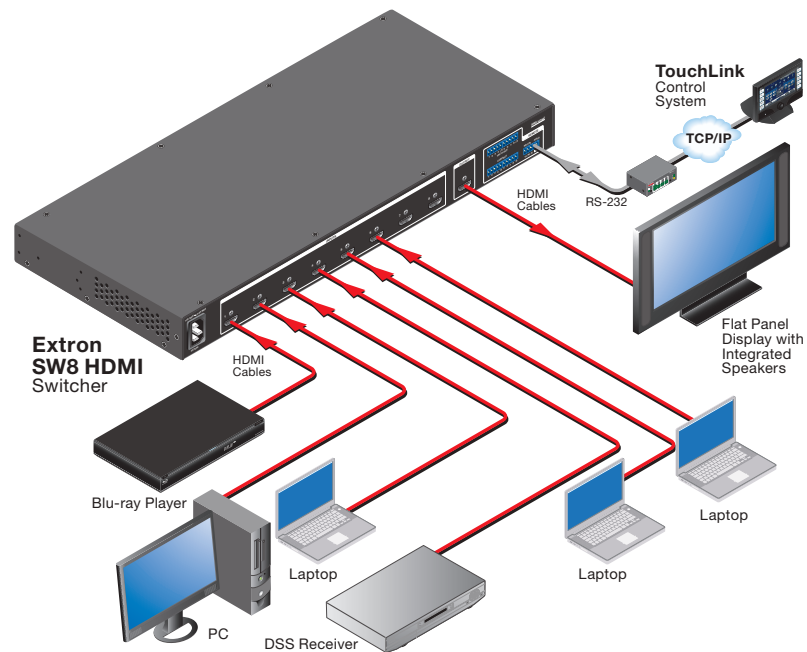

Figure 2. Application Diagram for an SW8 HDMI Switcher

Installation

This section describes the installation and setup of the SW HDMI Series switchers. Topics include:

- [Installation Overview](#)
- [Rear Panel Features](#)
- [Wiring the Power Connector — SW2 and SW4 HDMI Only \(Optional\)](#)
- [Wiring for RS-232 Control](#)
- [Connecting to the USB Port](#)
- [Enabling Auto-input Switching](#)
- [Wiring for Input Selection by Contact Closure](#)
- [Wiring the Tally Out Port to Indicate the Input Selection](#)

Installation Overview

To install and set up the SW HDMI switcher:

1. **Turn off all equipment** and disconnect it from the power source.
2. (Optional) **Mount the switcher** on a rack shelf or furniture (see [Mounting the SW HDMI](#) on page 33).
3. **Connect HDMI input sources** to one or more of the SW HDMI input connectors.
4. **Connect an HDMI output device** to the output connector.
5. **Connect control devices.** Connect your computer to either of the following SW HDMI ports to configure and control the switcher via SIS commands:
 - **RS-232 port** — Pins 1, 2, and 3 of the RS-232/Auto connector for serial RS-232 control (see [Wiring for RS-232 Control](#) on page 8 for connection procedures)
 - **Config port** — USB mini B connector for USB control (see [Connecting to the USB Port](#) on page 9 for connection procedures)
6. (Optional) **Enable auto-input switching.** Use a jumper to connect pins 4 and 5 of the 5-pole captive screw plug that you plugged into the RS-232 connector in step 5 (see [Enabling Auto-input Switching](#) on page 10).
7. (Optional) Connect an input device to the SW HDMI Contact port (directly or through a contact closure device) and, if desired, to the Tally Out port, to enable input switching by contact closure (see [Wiring for Input Selection by Contact Closure](#) on page 11).
8. **Power on the output display.**
9. **Connect power to the switcher** (see [Powering On the Switcher](#) on page 15).
10. (Optional) **Configure the EDID Minder.** By default, the SW HDMI is configured to automatically store the EDID of the display (automatic mode). If desired, change the EDID mode to prevent automatic EDID storage and enter the desired EDID manually (see [EDID Modes](#) on page 17).
11. **Power on the source devices.**

Rear Panel Features



Figure 3. SW2 HDMI Rear Panel

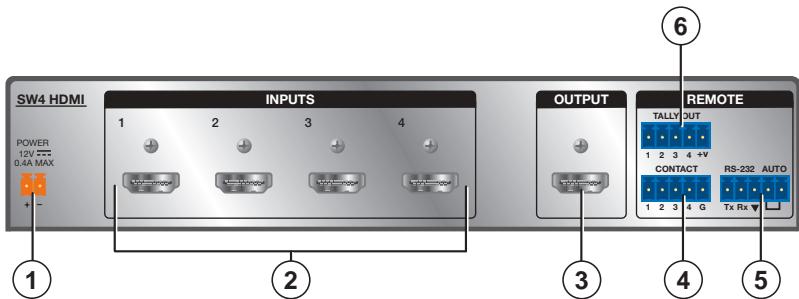

Figure 4. SW4 HDMI Rear Panel

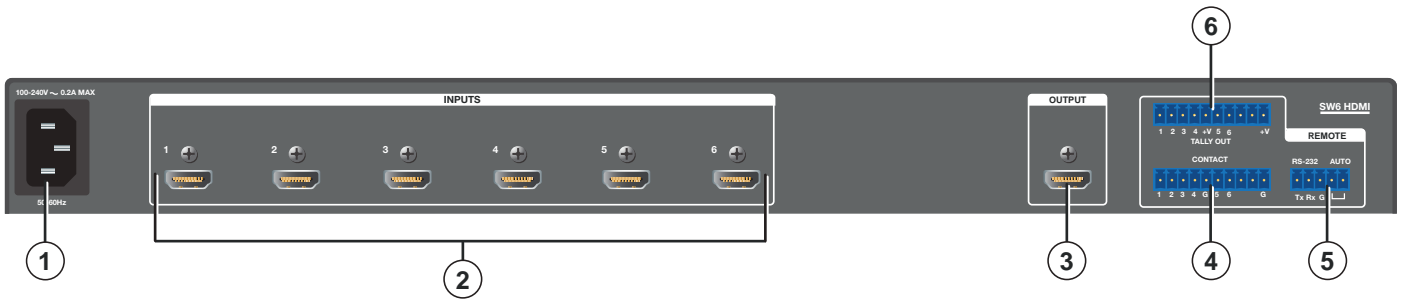

Figure 5. SW6 HDMI Rear Panel

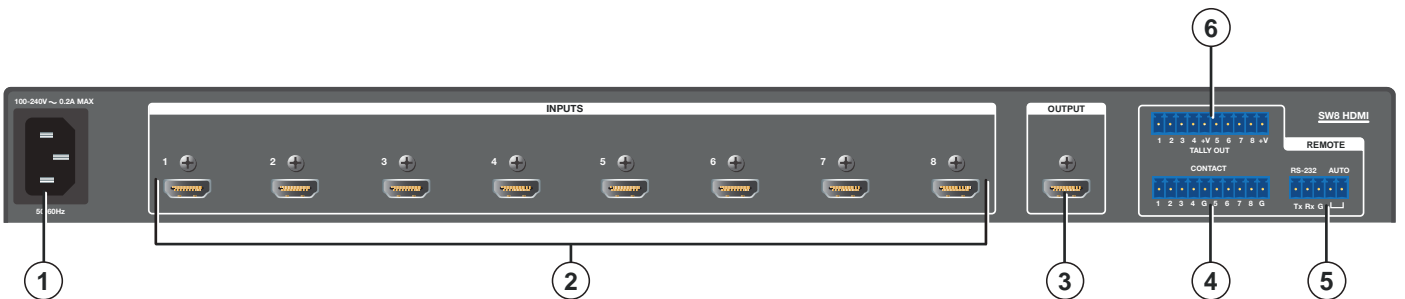

Figure 6. SW8 HDMI Rear Panel

① **Power connector** —

- **SW2 and SW4 HDMI:** Plug the provided external 12 VDC, 1 A power supply into this 2-pole, 3.5 mm captive screw connector and into an AC power outlet.

ATTENTION: Do not connect power to the switcher until you have read the **CAUTION and ATTENTION notices** on the next page.

- **SW6 and SW8 HDMI:** Plug the provided AC power cord into this male IEC connector and into an AC power outlet.

② **Input connectors** — Connect HDMI video input sources to these female Type A single-link HDMI connectors. Data rates of up to 6.75 Gbps are supported.

- **LockIt brackets:** LockIt cable lacing brackets, one for each HDMI input and the output connector, are provided with the SW HDMI. These brackets secure the HDMI cables to the rear panel connectors and reduce stress on the connectors, preventing signal loss due to loose cable connections. For information on attaching the LockIt brackets, see the *LockIt HDMI Cable Lacing Bracket Installation Guide*, available at www.extron.com.
- **EDID information:** By default, EDID is read from the output device and written to switcher memory for each input, allowing each source to see the EDID information for the output device even when the SW HDMI is switching between sources.

③ **Output connector** — Connect an HDMI display device to this female Type A HDMI connector.

The EDID information is read from the connected output device via this connector and is written to memory on each input whenever the output device is connected to this port and powered on.

NOTE: The EDID information is also read and stored whenever power is recycled to the connected output device or when the output device is replaced.

④ **Contact port** — Plug one of the provided 5-pole captive screw connectors into this 5-pole, 3.5 mm captive screw port. On the SW6 and SW8 HDMI, plug connectors into either or both parts of the dual Contact port. You can use this port to switch inputs by:

- Shorting the ground pin to any of the other four pins in the connector (see **Contact Closure** under “Selecting an Input” on page 15).
- Connecting a push-button contact closure device to the port (see **Wiring for Input Selection by Contact Closure** on page 11).

⑤ **Remote and auto-input switching connector** — This 5-pole, 3.5 mm captive screw connector (labeled “RS-232 Auto”) can be used for RS-232 communication with the switcher (including firmware updates) and to enable auto-input switching.

- **To enable RS-232 control,** connect the Tx (transmit), Rx (receive) and G (ground) pins to the serial port of your computer (see **Wiring for RS-232 Control** on page 8).
- **To enable auto-input switching,** short pins 4 and 5 of this connector together. In auto-input switch mode, the switcher automatically switches to the highest numbered active input (see **Enabling Auto-input Switching** on page 10).

- ⑥ **Tally Out port** — (Optional) Plug one of the provided 5-pole captive screw connectors into this 5-pole captive screw port to indicate which input has been selected. On the SW6 and SW8 HDMI, plug connectors into either or both parts of the dual Tally Out port.

Connect an indicator device such as an LED to the attached connector to identify the currently selected input when the front panel buttons are not visible (see [Wiring the Tally Out Port to Indicate the Input Selection](#) on page 12).

Wiring the Power Connector — SW2 and SW4 HDMI Only (Optional)

A 12 VDC, 1 A power supply is provided with the SW2 and SW4 HDMI. Should it be necessary to attach a 2-pole captive screw connector to your power supply, follow these instructions:

CAUTION: Risk of electric shock. The two power cord wires must be kept separate while the power supply is plugged in. Remove power before wiring.

ATTENTION:

- The power supply must not be permanently fixed to the building structure or similar structures.
- The power supply must not be located within environmental air handling spaces or the wall cavity.
- The installation must be in accordance with the applicable provisions of the National Electrical Code ANSI/NFPA 70, Article 725 and the Canadian Electrical Code, Part 1, Section 16.
- The power supply must be located in the same vicinity as the Extron AV processing equipment in an ordinary location, Pollution Degree 2, secured to a podium, a desk, or an equipment rack within a dedicated closet.
- Always use a power supply specified for the SW HDMI by Extron. Use of an unauthorized power supply voids all regulatory compliance certification and may cause damage to the supply and the switcher.

1. Cut the DC output cord to the length needed.
2. Strip the jacket to expose 3/16 inch (5 mm) of the conductors.

ATTENTION:

- Exposing more than 3/16 inch (5 mm) of the copper wires could allow the stripped wires to touch each other, causing a short circuit. This could result in the external DC power supply overheating and burning.
- Stripping the wires to expose less than the recommended amount may cause them to slide out of the connector too easily, even if they are tightly pinched by the captive screws.
- Do not tin the stripped power supply leads before attaching the captive screw plug to them. Tinned wires are not as secure in the captive screw connectors and can be easily pulled out. They may also break after being bent several times.

3. Slide the leads into the supplied 2-pole captive screw plug and secure them, using a small screwdriver.
4. To verify the power cord polarity before connecting the plug, connect the power supply with no load and check the output with a voltmeter.

- Use the supplied tie wrap to strap the power cord to the extended tail of the connector.

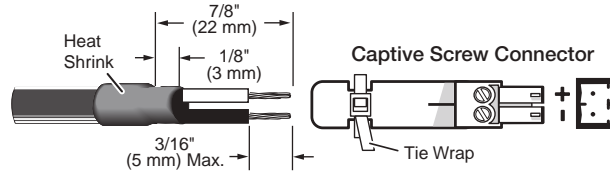

Figure 7. Wiring the Power Connector

Wiring for RS-232 Control

Use a female 9-pin D to bare wire RS-232 cable or a universal control cable (UC50' or UC100') to connect your computer or control system to the RS-232 pins of the Remote connector.

- Wire the unterminated end of the RS-232 cable to the provided 5-pole captive screw plug as described below. Connect the transmit, receive, and ground wires of the cable to the **first three pins** on the connector, starting at the left:
 - Connect the transmit wire to pin 1, which plugs into the Tx (transmit) port.
 - Connect the receive wire to pin 2, which plugs into the Rx (receive) port.
 - Connect the ground wire to pin 3, which plugs into the G (ground) port.
- Plug the 5-pole connector into the Remote receptacle on the rear panel of the switcher.
- Connect the other end of the cable to the appropriate computer or control system connector.

Figure 8 shows how to wire this shared connector for RS-232.

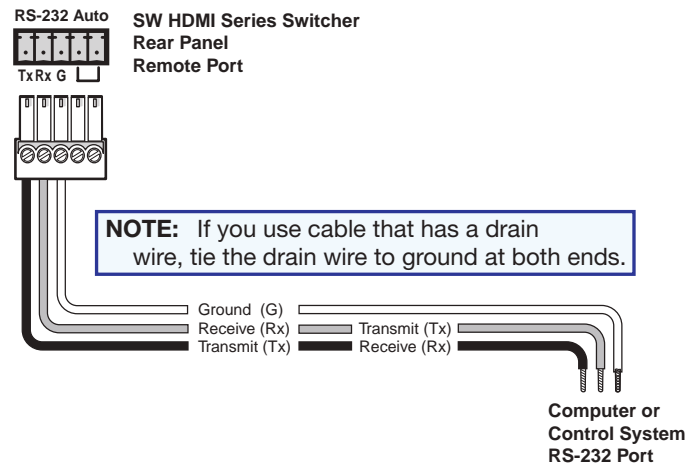

Figure 8. Remote Connector Pin Assignments

Connecting to the USB Port

The mini B USB port is located on the SW HDMI front panel. It can be used to configure the switcher via SIS commands.

1. Connect a USB A to mini B cable between the USB Config port on the switcher front panel and the USB port on your computer.

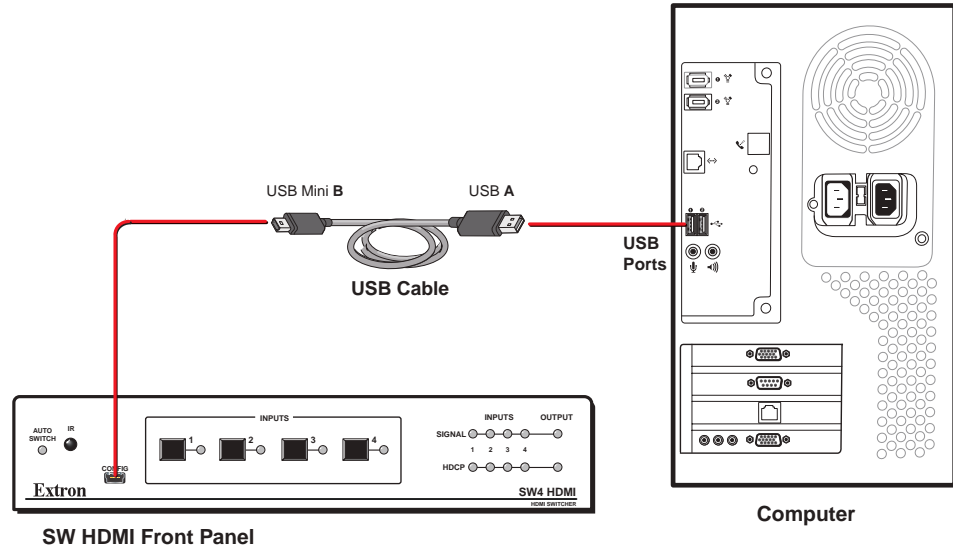

Figure 9. USB Port Connection

2. If this is the first time you have connected an SW HDMI to this USB port on your computer, the Found New Hardware Wizard opens. On the first screen, specify whether you want the computer to connect to Windows Update in order to search the web for the driver that it needs to communicate with the switcher via the USB port. This is not necessary if the USB driver already exists on your computer.



Figure 10. Found New Hardware Wizard Opening Screen

- Select the **Yes, this time only** radio button if you want your computer to connect to Windows Update only this one time.

- Select **Yes, now and every time I connect a device** if you want the computer to automatically connect to Windows Update to search the web every time the switcher is connected to this USB port.
 - Select **No, not this time** if you do not want the computer to connect to Windows Update to search the web at this time (for example, if the driver is already on your computer).
3. Click **Next**. On the next screen, select the **Install the software automatically (Recommended)** radio button, then click **Next** (you do not need to insert a disc).



Figure 11. Selecting the Radio Button to Install the USB Driver Automatically

Your computer locates the driver needed for it to communicate with the SW HDMI via the USB port and loads it to the computer hard drive.

4. When the Completed screen appears, click **Finish** to close the wizard.

NOTE: This wizard appears only the **first** time you connect the SW HDMI to each USB port. You do not see the wizard again unless you connect the switcher to a different USB port on your computer.

5. Configure the switcher as desired using SIS commands (see the **Remote Communication and Control** section, beginning on page 21 for information on available commands).

Enabling Auto-input Switching

You can set up the SW HDMI to automatically select the active, connected input based on detection of an active video signal (TMDS clock activity). If two or more inputs are active, the highest-numbered input port with an active signal is selected (for example, input 4 on an SW4 HDMI switcher). When auto-input switching is in effect, the green Auto Switch LED on the front panel lights and the front panel input buttons are disabled.

To enable auto-input switching:

1. Cut a small piece of wire to use as a jumper.
2. Insert the ends of the wire into slots 4 and 5 of the provided 5-pole captive screw plug, connecting pins 4 and 5 together.

3. Use a small screwdriver to tighten the two screws above pin slots 4 and 5 of the plug so that the jumper wire ends remain securely in place (see figure 12).
4. Insert the plug into the 5-pole Remote captive screw connector on the rear panel.

Figure 12 shows an SW4 HDMI with a jumper connecting pins 4 and 5 to enable auto-input switching.

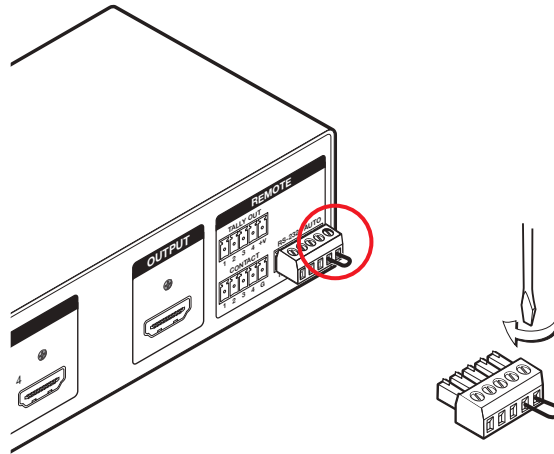

Figure 12. Auto Pins of the Remote Connector with a Jumper Installed

Auto-input switching remains in effect as long as the jumper wire connects the two pins and the 5-pole captive screw plug is attached to the RS-232/Auto port.

Wiring for Input Selection by Contact Closure

The Contact port provides an alternative method of input selection. Connect a push-button contact closure device to this port to switch the desired input to the output as follows:

1. Plug one of the provided 5-pole connectors into the Contact port. On the SW6 and SW8 HDMI, plug connectors into either or both parts of the dual Contact port.
2. Insert the signal wire of the contact closure device into the slot representing the desired input number on the SW HDMI Contact port.

Pin 1 = Input 1 contact

Pin 2 = Input 2 contact

Pin 3 = Input 3 contact (SW4, SW6, and SW8 HDMI only)

Pin 4 = Input 4 contact (SW4, SW6, and SW8 HDMI only)

Pin 5 (G) = Contact ground

Pin 6 = Input 5 contact (SW6 and SW8 HDMI only)

Pin 7 = Input 6 contact (SW6 and SW8 HDMI only)

Pin 8 = Input 7 contact (SW8 HDMI only)

Pin 9 = Input 8 contact (SW8 HDMI only)

Pin 10 (G) = Contact ground (SW6 and SW8 HDMI only)

3. Insert the ground wire of the contact device into the G slot of the Contact port (pin 5 or 10).

After wiring the connector, press the button on the contact device to switch the connected input to the output.

Wiring the Tally Out Port to Indicate the Input Selection

To identify the currently selected input when the front panel buttons are not visible, you can connect an indicator device such as an LED to an input pin and the +V pin of the Tally Out port. When the input you are using is selected, the corresponding tally out pin shorts to ground, which activates the connected indicator.

To connect an indicator to the Tally Out port:

1. Plug one of the provided 5-pole connectors into the Tally Out port. On the SW6 and SW8 HDMI, plug connectors into either or both parts of the dual Tally Out port.
2. Insert the power wire for the contact indicator device into the +V slot of the Tally Out connector (pin 5).
3. Insert the ground wire for the indicator into the slot on the Tally Out port that represents the input that you want to monitor.

Pin 1 = Input 1 tally ground

Pin 2 = Input 2 tally ground

Pin 3 = Input 3 tally ground (SW4, SW6, and SW8 HDMI only)

Pin 4 = Input 4 tally ground (SW4, SW6, and SW8 HDMI only)

Pin 5 = +5 V

Pin 6 = Input 5 tally ground (SW6 and SW8 HDMI only)

Pin 7 = Input 6 tally ground (SW6 and SW8 HDMI only)

Pin 8 = Input 7 tally ground (SW8 HDMI only)

Pin 9 = Input 8 tally ground (SW8 HDMI only)

Pin 10 = +5 V (SW6 and SW8 HDMI only)

Example: One way to use this port is to connect it to a contact closure device with an LED. Connect the contact device to the Contact port as well. When you use the contact device to switch the input you are using, the LED lights.

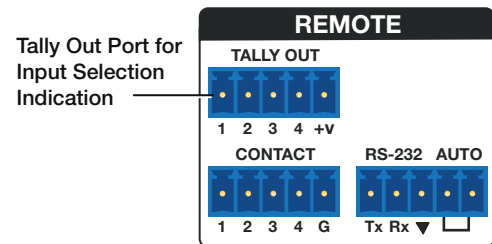

Operation

This section describes the operation of the SW HDMI Series switchers. Topics include:

- [Front Panel Features](#)
- [Operations](#)

Front Panel Features

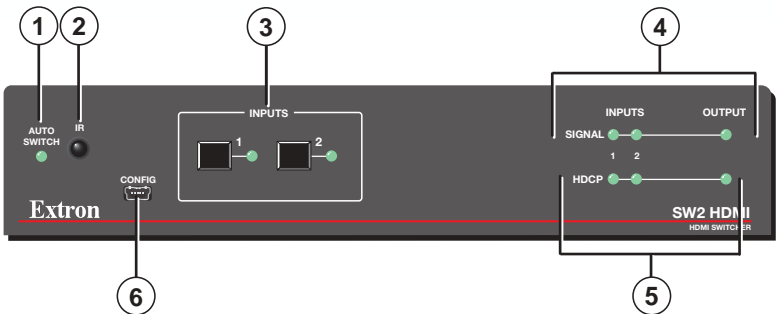

Figure 13. SW2 HDMI Front Panel

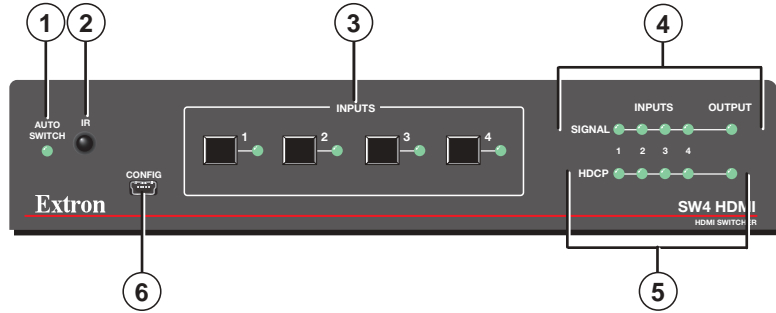

Figure 14. SW4 HDMI Front Panel

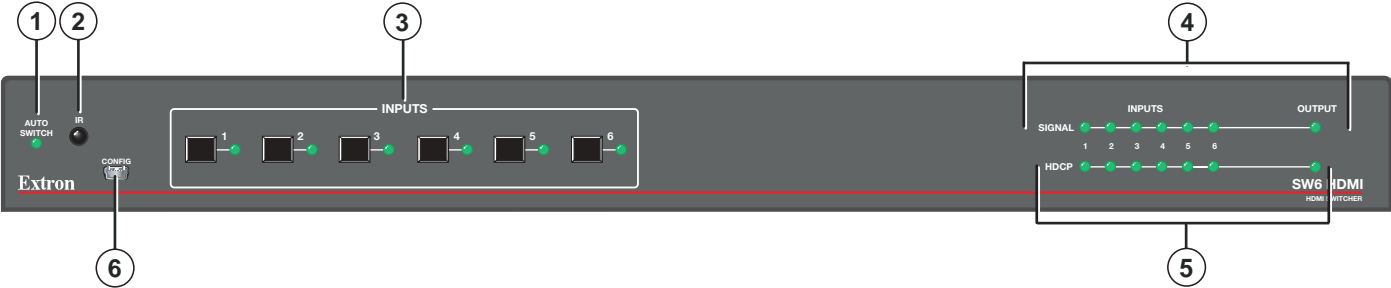

Figure 15. SW6 HDMI Front Panel

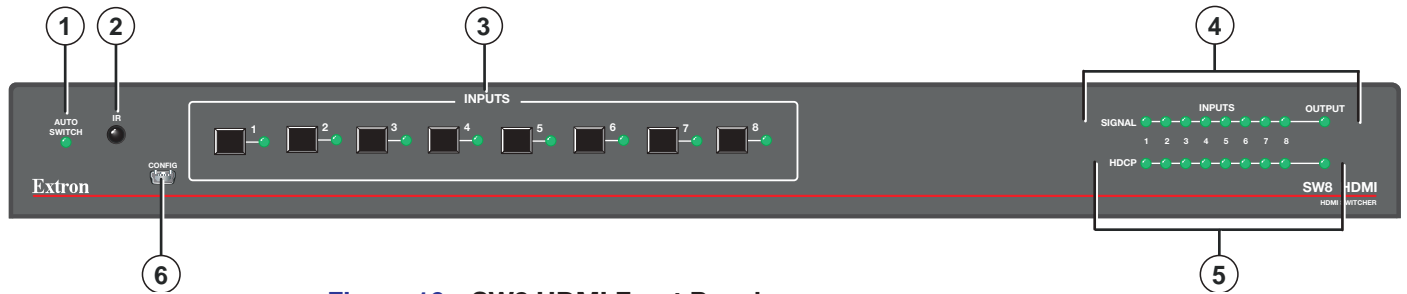

Figure 16. SW8 HDMI Front Panel

- ① **Auto Switch LED** — This LED lights when auto-input switching is in effect (see [Enabling Auto-input Switching](#) on page 10 for the procedure to set up automatic input selection).
- ② **IR receiver port** — This sensor detects infrared signals from the optional IR 102 remote control at a distance of up to 30 feet and within 40 degrees off the axis (see [Using the Optional IR 102 Remote Control](#) on page 16).
- ③ **Input selection buttons and LEDs** — Press one of these buttons to select an input to switch to the output. The LED at the right of each button lights when the corresponding input is selected. If auto-input switching is in effect, these buttons are disabled, but the LEDs continue to light to indicate the selected input. The input buttons are also used to initiate a system reset (see [Resetting](#) on page 16) and to enable and disable front panel lockout (see [Locking and Unlocking the Front Panel \(Executive Mode\)](#) on page 17).

④ **Signal status LEDs** —

- **Inputs:** Each input has a corresponding numbered Signal LED, which lights when a source is connected to the input connector and TMDS clock activity is detected on it.

NOTE: If the source device connected to the selected input is HDCP encrypted (requires HDCP authentication), the corresponding signal LED may not light unless HDCP has been authenticated.

- **Output:** The Output Signal LED lights when an active sink (output) device is connected to the HDMI output.

⑤ **HDCP status LEDs** —

- **Inputs:** Each input has a corresponding numbered HDCP LED. If the connected source requires HDCP, the corresponding LED lights when authentication is successful.

NOTE: HDCP is authenticated on each input regardless of the currently selected source.

- **Output:** The Output HDCP LED lights if the currently selected input requires HDCP and the connected output device has been successfully authenticated.

NOTE: HDCP is re-authenticated on the output whenever a new input is selected.

- ⑥ **Config port** — Connect a USB cable (USB A to mini B) between your computer and this female USB mini B port to configure and control the switcher via SIS commands or the Universal Switcher Control Program and to update the firmware (see [Connecting to the USB Port](#) on page 9).

Operations

Powering on the Switcher

To power on the SW HDMI:

1. Connect all input and output devices to the rear panel connectors on the switcher (see [Rear Panel Features](#) on page 5 for the rear panel connections).
2. Power on the display.
3. **Power on the SW HDMI:**
 - **SW2 and SW4 HDMI:** Plug the power supply into the 2-pole captive screw power connector on the switcher rear panel.
 - **SW6 and SW8 HDMI:** Plug the provided IEC cord into the rear panel IEC connector and an AC outlet.

After approximately 4 seconds, the following happens:

- The unit performs a self-test, during which the front panel Auto Switch, Input, Signal, and HDCP LEDs each blink once in sequence from left to right. When the self-test completes, the LED for the most recently selected input remains lit.
- The switcher reads the available EDID information from the connected output device and writes it to memory on each input. When power is removed, these settings remain in memory and are in effect when power is reapplied.

NOTE: If EDID Minder is in automatic mode, the settings revert to the default EDID unless a display is connected to the HDMI output port (see [EDID Modes](#) on page 17).

4. Power on the input devices.

Selecting an Input

To switch (tie) an input to the output, you have the following options:

- **Front panel buttons:** Press the desired input button on the front panel (ensure that auto-input switching is not enabled). The LED corresponding to the selected input button lights.
 - The appropriate front panel input LED lights to indicate the selected input. The LED remains lit until a new input is selected.
 - Only one input can be switched to the output at a time.
- **Contact closure:** Plug one of the provided 5-pole captive screw connectors into the rear panel Contact port. Wire either of the following to the port:
 - **Contact closure device:** If a push-button contact closure device is attached to the Contact port, press the button that is connected to the slot that corresponds to the desired input.
 - **Jumper wire:** On the connector attached to the Contact port, momentarily short one of the input pins (1 through 8, depending on your model) to the ground pin (pin G) using a jumper wire. For example, shorting pin 1 to pin G selects input 1. Input is switched immediately when the jumper contacts both pins.

NOTE: If an input pin is latched permanently to the ground pin, input switching by any other method is disabled while those pins are connected.

See [Wiring for Input Selection by Contact Closure](#) on page 11 for more information.

Other ways to select an input include using SIS commands (see the [Input Selection](#) command on page 24) and optional IR remote control (see “Using the Optional IR 102 Remote Control”).

Resetting

To reset the switcher to its factory default settings:

1. Press and hold the Input 1 button while power is being applied to the unit.
2. Continue holding the Input 1 button until the power-up sequence completes.

Using the Optional IR 102 Remote Control

The optional hand-held IR 102 Remote Control lets you remotely perform functions that are also available through the front panel buttons and SIS commands.

The IR receiver port on the front panel is located to the right of the Auto Switch LED. It receives signals from the remote control if they are sent from within a 40-degree arc to the right or left of the IR receiver sensor, and from no more than 30 feet (9 m) away (see figure 17).

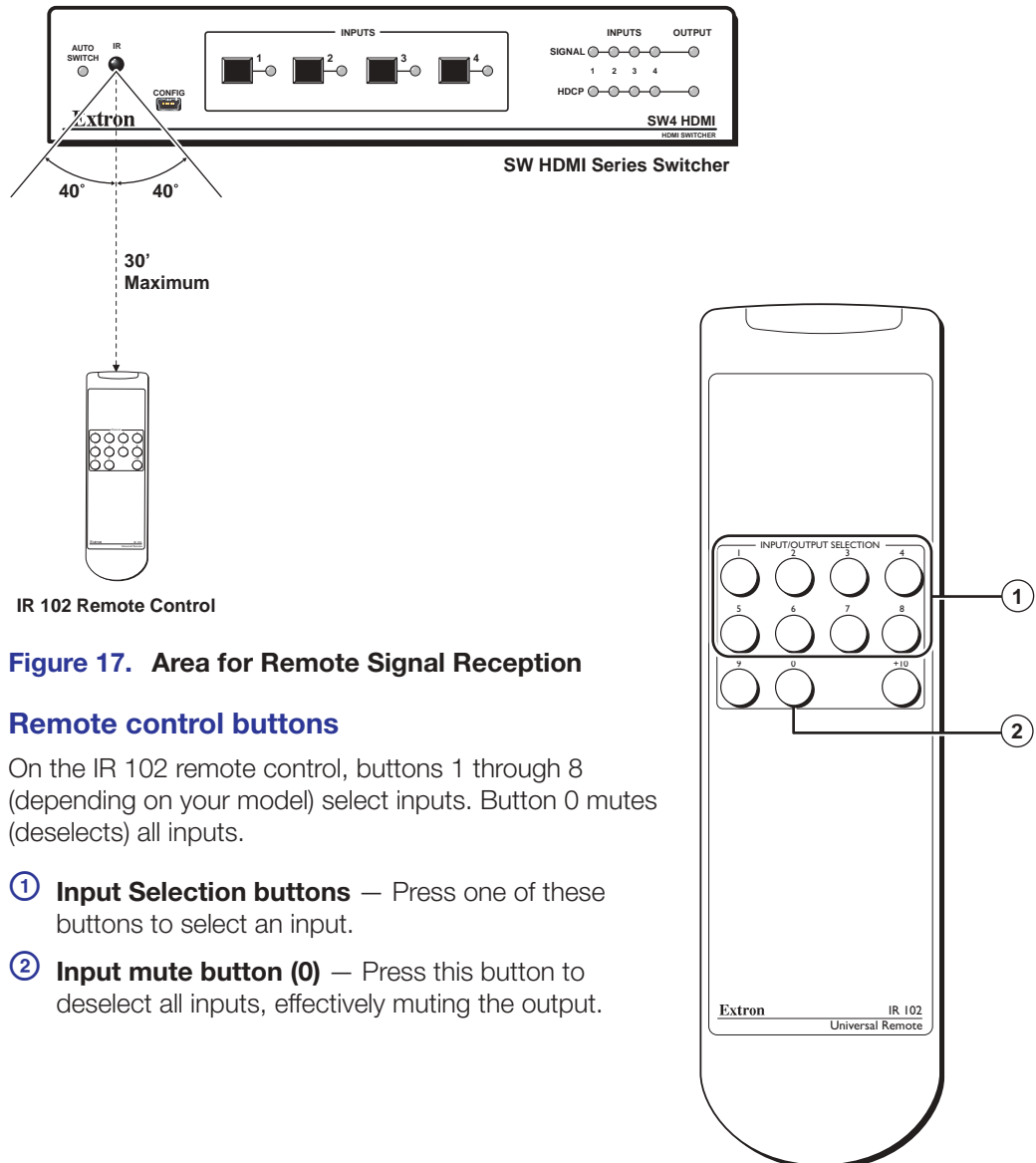

IR 102 Remote Control

Figure 17. Area for Remote Signal Reception

Remote control buttons

On the IR 102 remote control, buttons 1 through 8 (depending on your model) select inputs. Button 0 mutes (deselects) all inputs.

- ① **Input Selection buttons** — Press one of these buttons to select an input.
- ② **Input mute button (0)** — Press this button to deselect all inputs, effectively muting the output.

Locking IR remote access

The SW HDMI can be set to lock out users from using the IR 102 Remote Control to control the switcher. Remote access can be enabled and disabled via SIS commands (see the **Front Panel IR Receiver Enable and Disable** commands on page 25). When remote access is disabled, all switcher controls remain available through the SW HDMI front panel.

Locking and Unlocking the Front Panel (Executive Mode)

Front panel lock mode disables all front panel controls, locking out users from those functions (RS-232, USB, and IR control remain available). Putting the switcher in lock mode enhances security by protecting against inappropriate or accidental changes to settings. If a front panel button is pressed during lock mode, all front panel LEDs blink once.

To lock or unlock the front panel, press and hold Input buttons 1 and 2 simultaneously for 3 seconds, then release. The front panel LEDs blink three times, indicating that executive mode has been enabled or disabled (see figure 18).



Figure 18. Enabling or Disabling Executive Mode

EDID Modes

The SW HDMI switchers utilize the EDID Minder, which maintains EDID communication to all connected sources, whether or not any of the sources are selected. EDID information consists of the display resolution, refresh rate, data rate, supported audio formats, and other parameters. By factory default, the EDID stored on all inputs contains information for a native resolution of 720p @ 60 Hz, 2-channel audio.

EDID Minder can be configured in two modes: automatic and user-assigned.

Automatic EDID mode

In automatic mode, the switcher automatically stores EDID from the connected display and communicates it to the inputs; no other configuration is required. This is the default mode.

- **Reading and storage process** — Each time a display is connected to the HDMI output while the power is connected, the SW HDMI reads the EDID from the display device and stores it in memory for each input. This information is retained after the display is disconnected. However, it is overwritten if a new display is connected or a user assigned EDID file is selected.
- **Default EDID** — When the switcher is in automatic mode, the default EDID (720p @ 60 Hz, 2-channel audio) is stored at each input until a display is connected, at which time it is overwritten.

User-assigned EDID mode

In this mode, you can select an EDID file that is stored on the switcher. The selected EDID is stored in memory for the inputs and is not overwritten. The switcher does not obtain EDID information from the display.

You may want to use this mode if there is a problem with automatic communication of the EDID information from the attached display, and you want to ensure that the correct information is stored on the inputs. Also, because this mode disables automatic EDID reading and storage, you can retain one set of EDID information on the inputs and not have it changed when another display is connected.

- **Factory-loaded EDID files** — You can select from a list of 48 EDID files that are loaded on the switcher at the factory. Each EDID file contains a unique native resolution (and audio support if applicable). The **EDID table** on the next page shows the EDID files that are provided with the switcher.
- **User-loaded EDID file** — In addition to the 48 EDID files provided with the switcher, four empty memory locations (50 through 53) are provided. You can use these memory locations to save the EDID of the display that is currently connected to the output port of the switcher. Any of these four EDID files can then be selected as one of the user-assigned EDID files.

Changing the EDID mode

EDID modes can be switched only by SIS command. By default, the SW HDMI is in automatic EDID mode. To change between automatic and user-assigned modes, enter the following SIS command:

Esc A **X4** EDID ←

where **X4** is 49 (auto mode) or the number of the user-assigned EDID file that you want to select (1 through 53) (see the **Remote Communication and Control** section, beginning on page 21, for instructions for entering SIS commands via RS-232 or USB).

NOTE: The switcher remains in the selected EDID mode after power is recycled. If the unit is reset to factory defaults, it reverts to automatic mode.

See the **table on the next page** for a list of supported EDIDs.

EDID table

EDIDs listed in this table are arranged according to video format: DVI or HDMI. Within each video format grouping, the EDIDs are listed by rate type: PC or HDTV. Within each rate type grouping, the EDIDs are listed in order of resolution.

<input checked="" type="checkbox"/>	Native Resolution	Refresh Rate	Rate Type ¹	Video Format ²	Audio Type ³	<input checked="" type="checkbox"/>	Native Resolution	Refresh Rate	Rate Type ¹	Video Format ²	Audio Type ³
1	800 x 600	60 Hz	PC	DVI	n/a	28	1680 x 1050	60 Hz	PC	HDMI	2-Ch
2	1024 x 768	60 Hz	PC	DVI	n/a	29	1920 x 1200	60 Hz	PC	HDMI	2-Ch
3	1280 x 720	60 Hz	PC	DVI	n/a	30	2048 x 1080	60 Hz	PC	HDMI	2-Ch
4	1280 x 768	60 Hz	PC	DVI	n/a	31	480p	60 Hz	HDTV	HDMI	2-Ch
5	1280 x 800	60 Hz	PC	DVI	n/a	32	576p	50 Hz	HDTV	HDMI	2-Ch
6	1280 x 1024	60 Hz	PC	DVI	n/a	33	720p	50 Hz	HDTV	HDMI	2-Ch
7	1360 x 768	60 Hz	PC	DVI	n/a	34	720p (default)	60 Hz	HDTV	HDMI	2-Ch
8	1366 x 768	60 Hz	PC	DVI	n/a	35	1080i	50 Hz	HDTV	HDMI	2-Ch
9	1400 x 1050	60 Hz	PC	DVI	n/a	36	1080i	60 Hz	HDTV	HDMI	2-Ch
10	1440 x 900	60 Hz	PC	DVI	n/a	37	1080p	50/25 Hz	HDTV	HDMI	2-Ch
11	1600 x 900	60 Hz	PC	DVI	n/a	38	1080p	50	HDTV	HDMI	2-Ch
12	1600 x 1200	60 Hz	PC	DVI	n/a	39	1080p	60/24 Hz	HDTV	HDMI	2-Ch
13	1680 x 1050	60 Hz	PC	DVI	n/a	40	1080p	60 Hz	HDTV	HDMI	2-Ch
14	1920 x 1080	60 Hz	PC	DVI	n/a	41	720p	50 Hz	HDTV	HDMI	Multi-Ch
15	1920 x 1200	60 Hz	PC	DVI	n/a	42	720p	60 Hz	HDTV	HDMI	Multi-Ch
16	2048 x 1080	60 Hz	PC	DVI	n/a	43	1080i	50 Hz	HDTV	HDMI	Multi-Ch
17	800 x 600	60 Hz	PC	HDMI	2-Ch	44	1080i	60 Hz	HDTV	HDMI	Multi-Ch
18	1024 x 768	60 Hz	PC	HDMI	2-Ch	45	1080p	50/25 Hz	HDTV	HDMI	Multi-Ch
19	1280 x 768	60 Hz	PC	HDMI	2-Ch	46	1080p	50 Hz	HDTV	HDMI	Multi-Ch
20	1280 x 800	60 Hz	PC	HDMI	2-Ch	47	1080p	60/24 Hz	HDTV	HDMI	Multi-Ch
21	1280 x 1024	60 Hz	PC	HDMI	2-Ch	48	1080p	60 Hz	HDTV	HDMI	Multi-Ch
22	1360 x 768	60 Hz	PC	HDMI	2-Ch	49	Automatic (output)				
23	1366 x 768	60 Hz	PC	HDMI	2-Ch	50	User-loaded slot 1				
24	1400 x 1050	60 Hz	PC	HDMI	2-Ch	51	User-loaded slot 2				
25	1440 x 900	60 Hz	PC	HDMI	2-Ch	52	User-loaded slot 3				
26	1600 x 900	60 Hz	PC	HDMI	2-Ch	53	User-loaded slot 4				
27	1600 x 1200	60 Hz	PC	HDMI	2-Ch						

^{1,2,3} See [Footnotes for the EDID table](#) on the next page.

Footnotes for the EDID table

The following footnotes apply to the EDID table on the previous page:

¹Rate type

- **PC:** These are primarily VESA standard computer rates, based on the most commonly used native resolutions. They are designed to be used with computer sources.
- **HDTV:** These are video rates standardized by SMPTE and CEA. They are designed to be used with video and computer sources.

²Video format

DVI: These are 128-byte EDID files, which specify a DVI sink. They do not contain an extension block.

HDMI: These are 256-byte EDID files, each containing a CEA extension block. They each specify an HDMI sink device with audio support.

³Audio type

- **n/a:** These are DVI formatted EDID files. They do not support audio.
- **2-Ch:** These are HDMI formatted EDID files with support for basic 2-channel (stereo) audio.
 - LPCM (2-Ch)
- **Multi-Ch:** These are HDMI formatted EDID files with support for multiple audio formats up to 8 channels.
 - LPCM (2-Ch)
 - LPCM (8-Ch)
 - Dolby® Digital (6-Ch)
 - DTS® (7 Ch)
 - Dolby Digital Plus (8-Ch)
 - DTS-HD (8-Ch)
 - Dolby TrueHD (8-Ch)

Remote Communication and Control

This section describes remote operation of the SW HDMI switchers. Topics include:

- [Using Simple Instruction Set \(SIS\) Commands](#)
- [Updating Firmware Using Firmware Loader](#)

Using Simple Instruction Set (SIS) Commands

The SW HDMI can be remotely set up and controlled via Extron SIS commands that are issued from a host computer or other device, such as a control system. SIS commands can be issued via RS-232 from the computer serial port to the rear panel Remote port, or via USB from the computer USB port to the front panel Config port (see [Wiring for RS-232 Control](#) on page 8 or [Connecting to the USB Port](#) on page 9 to connect to these ports).

Host-to-switcher Communications

SIS commands consist of one or more characters per field. No special characters are required to begin or end a command sequence. You can enter these commands from your computer using a communication software program such as Extron DataViewer or HyperTerminal. When the switcher determines that a command is valid, it executes the command and sends a response to the host device.

Most responses from the SW HDMI to the host computer end with a carriage return and a line feed (CR/LF = **↵**), which signals the end of the response character string. A string is one or more characters.

Switcher-initiated Messages

When a local event such as a front panel selection or a change in signal status takes place, the switcher responds by sending a message to the host, indicating what change has occurred. No response is required from the host.

The switcher sends the following message when it is first powered on:

(C) Copyright 20nn, Extron Electronics HDMI Switcher Series, Vn.nn,
60-841-nn

20nn is the year in which the copyright for the firmware was registered, Vn.nn is the firmware version number, and 60-841-nn is the switcher part number.

NOTE: This message is displayed at power-up only with an RS-232 connection.

Error Responses

If the switcher is unable to execute a command it receives because the command is invalid or contains invalid parameters, the switcher returns an error response to the host. The following error response codes can be sent:

- E01 – Invalid input channel number (out of range)
- E06 – Invalid input selection during auto-input switching
- E10 – Invalid command
- E13 – Invalid value (out of range)

Using the Command and Response Table

The **command and response table**, starting on page 24, lists valid ASCII and hexadecimal command codes, the switcher responses to the host, and a description of the command function or the results of executing the command.

The conversion table below is for use with the command and response table.

ASCII to Hex Conversion Table															
Space →	20	!	21	"	22	#	23	\$	24	%	25	&	26	'	27
	(28)	29	*	2A	+	2B	,	2C	-	2D	.	2E	/
	0	30	1	31	2	32	3	33	4	34	5	35	6	36	7
	8	38	9	39	:	3A	;	3B	<	3C	=	3D	>	3E	?
	@	40	A	41	B	42	C	43	D	44	E	45	F	46	G
	H	48	I	49	J	4A	K	4B	L	4C	M	4D	N	4E	O
	P	50	Q	51	R	52	S	53	T	54	U	55	V	56	W
	X	58	Y	59	Z	5A	[5B	\	5C]	5D	^	5E	_
	`	60	a	61	b	62	c	63	d	64	e	65	f	66	g
	h	68	i	69	j	6A	k	6B	l	6C	m	6D	n	6E	o
	p	70	q	71	r	72	s	73	t	74	u	75	v	76	w
	x	78	y	79	z	7A	{	7B		7C	}	7D	~	7E	DEL
															0A

Figure 19. ASCII to Hex Conversion Table

Symbol Definitions

- ↵ = CR/LF (carriage return with line feed) (hex 0D 0A)
- ↵ or | = Soft carriage return (no line feed)
- = Space
- Esc or W = Escape
- X1 = Input number
 - 0 through the maximum number of inputs on the unit
 - 0 = Deselect (mute) all inputs
- X2 = On and Off, or mute status
 - 0 = Off or unmuted
 - 1 = On or muted
- X3 = Video color bit depth mode
 - 0 = Automatically truncate based on output
 - 1 = Force truncation to 8-bit
- X4 = EDID mode and file selection
 - 1-48 = Factory-supplied EDID number (for a list of available EDID files, see the [EDID table](#) on page 19).
 - 49 = Automatic mode (default). The EDID of the connected display is detected and passed to the inputs.
 - 50-53 = User-assigned EDID
- X5 = Current EDID information in hexadecimal format (128 or 256 bytes of hex data)
- X6 = Native resolution and refresh rate (translated from hexadecimal)
- X7 = Firmware version (to the second decimal place)
- X8 = Front panel lockout enabled or disabled
 - 0 = Front panel unlocked
 - 1 = Front panel locked
- X9 = HDCP authentication
 - 0 = HDCP not authenticated
 - 1 = HDCP authenticated
- X10 = Signal status
 - 0 = No signal detected
 - 1 = Signal detected
- X11 = On and off or enabled and disabled status
 - 0 = Off or disabled
 - 1 = On or enabled
- X12 = Switch mode
 - 1 = Normal (manual)
 - 2 = Auto-input
- X13 = Unit name. The name can have up to 24 alphanumeric characters including hyphens (-), with no spaces. The first character must be a letter, and the last character cannot be a hyphen. The default is SW-HDMI-SERIES.

NOTE: Unless otherwise indicated, commands are **not** case-sensitive.

Command and Response Table for SIS Commands

Command	ASCII Command (Host to Switcher)	Response (Unit to Switcher)	Additional Description
Input Selection			
Select input	<code>[X1] !</code>	In [X1] • All ←	Select input [X1]. [X1] = input number: 0 through the highest numbered input on the unit (2, 4, 6, or 8). 0 = deselect all inputs (disable output).
Video Muting			
Video mute	<code>[X2] B</code>	Vmt [X2] ←	Mute the video signal.
View video mute status	<code>B</code>	[X2] ←	Show video muting status [X2]. For [X2]: 1 = muted, 0 = unmuted (default)
Audio Muting			
Audio mute	<code>[X2] Z</code>	Amt [X2] ←	Mute the audio signal.
View audio mute status	<code>Z</code>	[X2] ←	Show audio muting status [X2]. For [X2]: 1 = muted, 0 = unmuted (default)
Video Color Bit Depth			
Set video color bit depth mode	<code>[Esc] V [X3] BITD ←</code>	Bitd V [X3] ←	Select color bit depth mode [X3]. For [X3]:
View video color bit depth mode	<code>[Esc] V BITD ←</code>	[X3] ←	0 = automatic, based on the EDID of the connected output (default). 1 = Force truncation to 8-bit.
Signal Status			
Request status of all signals	<code>[Esc] LS ←</code>	Sig [X10] • [X10] * [X10] ← (SW2 HDMI) or Sig [X10] • . . . • [X10] * [X10] ← (All other models)	Show signal presence or absence for all inputs and the output. For [X10]: 0 = no signal detected. 1 = signal detected.
Request HDCP status	<code>[Esc] HDCP ←</code>	Hdcp [X9] • [X9] * [X9] ← (SW2 HDMI) or Hdcp [X9] • . . . • [X9] * [X9] ← (All other models)	Show HDCP status [X9] for all inputs. For [X9]: 0 = HDCP not authenticated. 1 = HDCP authenticated.
EDID Minder			
Assign EDID to inputs	<code>[Esc] A [X4] EDID ←</code>	Edid A [X4] ←	Select an EDID file for all inputs. [X4] = EDID file location number: 1 – 48 = Factory-supplied EDID (see the EDID table on page 19). 49 = Automatic mode (default): EDID of the connected display is detected and passed to the inputs. 50 – 53 = User-loaded EDID.
<i>Example:</i>	<code>[Esc] A 9 EDID ←</code>	Edid A 9 ←	Select EDID file 9 (1400 x 1050 @ 60 Hz) to be stored in memory for the inputs.
View EDID assignment	<code>[Esc] A EDID ←</code>	[X4] ←	Show the number ([X4]) of the EDID file currently assigned to the inputs.
View EDID in hex format	<code>[Esc] R EDID ←</code>	[X5] ←	View the current EDID assignment in hexadecimal (256 bytes). [X5] = current EDID information in hex.

Command	ASCII Command (Host to Switcher)	Response (Unit to Switcher)	Additional Description
EDID Minder (continued)			
Save display EDID to user location	[Esc] S [X4] EDID ←	Edid S [X4] ↵	Store the EDID of the connected display as user-assigned EDID file [X4]. [X4] = 50 through 53
View EDID native resolution	[Esc] N EDID ←	[X6] ↵	Show native resolution and refresh rate [X6] from current EDID selection.
<i>Example</i>	[Esc] N EDID ←	1600x1200 @ 60 Hz ↵	
HDCP Authorized Device			
Enable or disable HDCP authentication per input	[Esc] E [X1] * [X2] HDCP ←	Hdcp E [X1] * [X2] ↵	Set HDCP authentication for input [X1] to [X2]. For [X2]: 0 = Disable HDCP authentication 1 = Enable HDCP authentication (default)
Enable or disable HDCP authentication for all inputs	[Esc] E [X2] HDCP ←	Hdcp E [X2] ↵	Set HDCP authentication to [X2] for all inputs.
View HDCP authentication status	[Esc] E HDCP ←	Hdcp E [X2] ... [X2] ↵	View the current HDCP authentication setting.
Front Panel Lockout			
Enable or disable lock mode	[X8] X	Exe [X8] ↵	Select front panel lock mode [X8]. For [X8]: 1 = locked, 0 = unlocked (default)
View lockout status	X	[X8] ↵	Show executive mode status.
Front Panel IR Receiver Enable and Disable			
Enable and disable IR receiver	[X11] * 65#	IRDisable [X11] ↵	Disable the IR remote receiver on the front panel from receiving signals from the IR remote control.
View IR status	65#	[X11] ↵	View IR receiver status [X11]. For [X11]: 0 = IR Disable feature is off (IR enabled) (default). 1 = IR Disable feature is on (IR disabled).
Unit Name			
Set unit name	[Esc] [X13] CN ←	Ipn • [X13] ↵	Assign name [X13] for the switcher. [X13] can consist of up to 24 alphanumeric characters, including the hyphen (-).
Set name to factory default	[Esc] • CN ←	Ipn • SW-HDMI-SERIES ↵	
View unit name	[Esc] CN ←	[X13] ↵	Show the current switcher name ([X13]).
Information Requests			
Request information	I	V [X1] • F [X12] • Vmt [X2] • Amt [X2] ↵	Show the selected video inputs, switch mode, video muting status, and audio muting status (audio models only). [X1] = input number: 1 through highest number of inputs available. [X2] = video or audio mute status. For [X2]: 1 = muted, 0 = unmuted [X12] = Switch mode. For [X12]: 1 = normal, 2 = auto-input mode
<i>Example:</i>	I	V4 • F2 • Vmt0 • Amt0 ↵	

Command	ASCII Command (Host to Switcher)	Response (Unit to Switcher)	Additional Description
Information Requests (continued)			
Request part number	N	60-nnn-nn ↵	Show the part number of the switcher: SW6 HDMI: 60-841-03 SW8 HDMI: 60-841-04 SW2 HDMI: 60-841-21 SW4 HDMI: 60-841-22
Query firmware version	Q	x7 ↵	Show firmware build number x7, expressed to the second decimal place.
<i>Example:</i>	Q	1.01 ↵	
Query auto-input switching status	72#	Asw x11 ↵	Show status of auto-input switching. For x11: 0 = disabled, 1 = enabled
Resetting			
Reset	Esc ZXXX ←	Zpx ↵	Reset the switcher to its factory default values.

Updating Firmware Using Firmware Loader

Updates to the SW HDMI Series firmware are made available periodically via the Extron website. You can find out what version of firmware is currently loaded on your switcher by entering the **SIS Q** command via the RS-232 or USB interface (see the **Query Firmware Version** command on the previous page).

Downloading and Installing Firmware Loader

Extron recommends using the Firmware Loader software to update the firmware on the SW HDMI. If you do not already have Firmware Loader installed on your computer, download it as follows:

1. Go to www.extron.com and click the **Download** tab.
2. On the Download Center screen, click the **Software** link on the left sidebar menu.
3. On the next Download Center screen, locate Firmware Loader and click its **Download** link.



Figure 20. Firmware Loader Download Link

4. On the next screen, enter the requested information, then click the **Download fw_loader_vnxxn.exe** button (where *nxn* is the Firmware Loader version number).
5. Follow the instructions on the rest of the download screens to save the executable Firmware Loader installer file to your computer. Note the folder to which the file was saved.
6. In the file browser, locate the downloaded executable installer file and double-click it to open it.
7. Follow the instructions on the Installation Wizard screens to install Firmware Loader on your computer. Unless you specify otherwise, the installer program places the Firmware Loader files at `c:\Program Files [(x86)]\Extron\FWLoader`.

Downloading the SW HDMI Firmware

To obtain the latest version of firmware for the SW HDMI:

1. Go to www.extron.com, click the **Download** link at the top of the page, then click the **Firmware** link on the left sidebar menu.



Figure 21. Firmware Link on the Download Tab

2. On the next Download Center screen, click the SW2/4 HDMI or SW6/8 HDMI **Download** link.

3. On the next screen that appears, enter the requested user information, then click the **Download** button.
4. Follow the instructions on the rest of the download screens to save the executable firmware file to your computer. Note the folder to which the file was saved.
5. In the file browser, locate the downloaded executable file, and double-click it to open it.
6. Follow the instructions on the Installation Wizard screens to install the new firmware on your computer. A Release Notes file, providing information on what has changed in the new firmware version, and a set of instructions for updating the firmware are also loaded.

NOTE: When downloaded from the Extron website, by default the firmware is placed in a folder at:
C:\Program Files\Extron\Firmware\SW HDMI (Windows XP) or
C:\Program Files (x86)\Extron\Firmware\SW HDMI (Windows 7).

Loading the Firmware to the Switcher

To load a new version of firmware to the switcher using Firmware Loader:

1. Connect your computer to the SW HDMI via either the first three pins of the switcher Remote port (see [Wiring for RS-232 Control](#) on page 8) or the front panel USB port (see [Connecting to the USB Port](#) on page 9).
2. If you have not already done so, download and install the Firmware Loader executable installer file to your computer (see [Downloading and Installing Firmware Loader](#) on the previous page).
3. If necessary, download the latest version of SW HDMI firmware and install it on your computer (see [Downloading the SW HDMI Firmware](#) on the previous page).
4. Open the Firmware Loader via your desktop **Start** menu by making the following selections:
Start > All Programs > Extron Electronics > Firmware Loader > Firmware Loader
The Firmware Loader window opens with the Add Device window displayed in front (see [figure 22](#) on the next page).
5. On the Add Device window, select **SW HDMI Series** from the **Device Name** drop-down menu.
6. From the **Connection Method** drop-down menu, select either **RS-232** or **USB**.

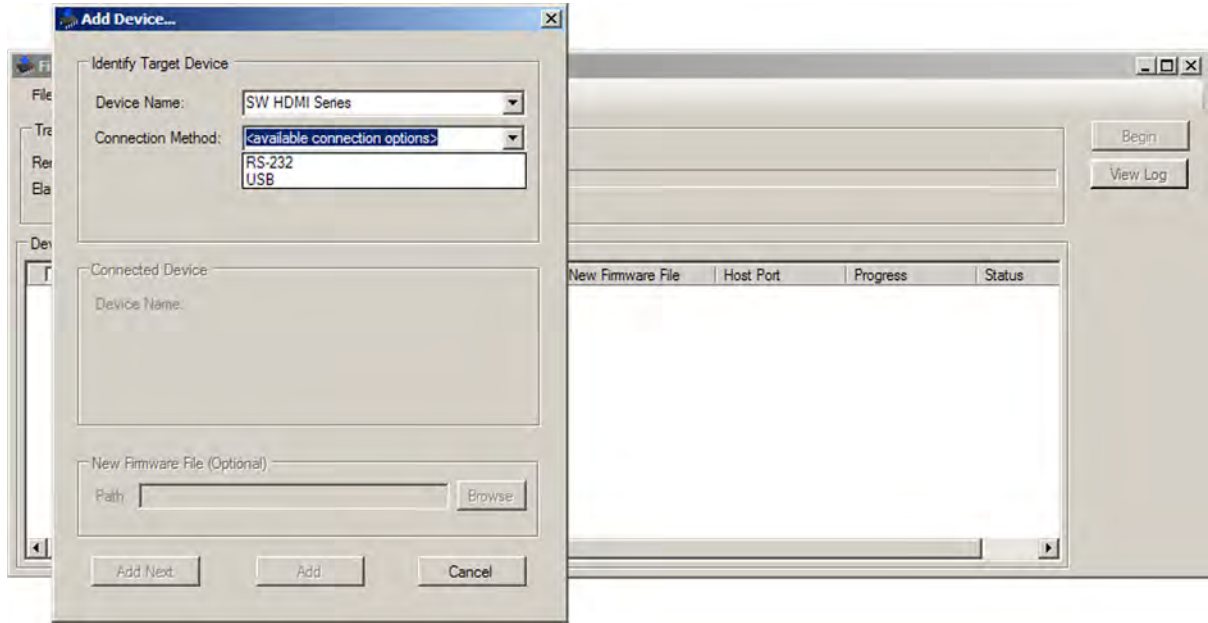

Figure 22. Connection Method Menu on the Add Device Window

7. Depending on the connection method that you selected, additional options appear. Make the appropriate selections for your connection method.
 - **RS-232:** Select the appropriate options from the **Com Port** and **Baud Rate** menus (this information is provided by your system administrator).
 - **USB:** Only the **Extron USB Device_0** option is available on the **Available Devices** menu. Make sure that it is selected.
8. Click **Connect**. If the connection is successful, **SW HDMI Series** is displayed in green in the Connected Device section, followed by a green check mark.
9. Click the **Browse** button in the New Firmware File (Optional) section.
10. On the Open window, navigate to the new firmware file, which has an **S19** extension, and double-click it.

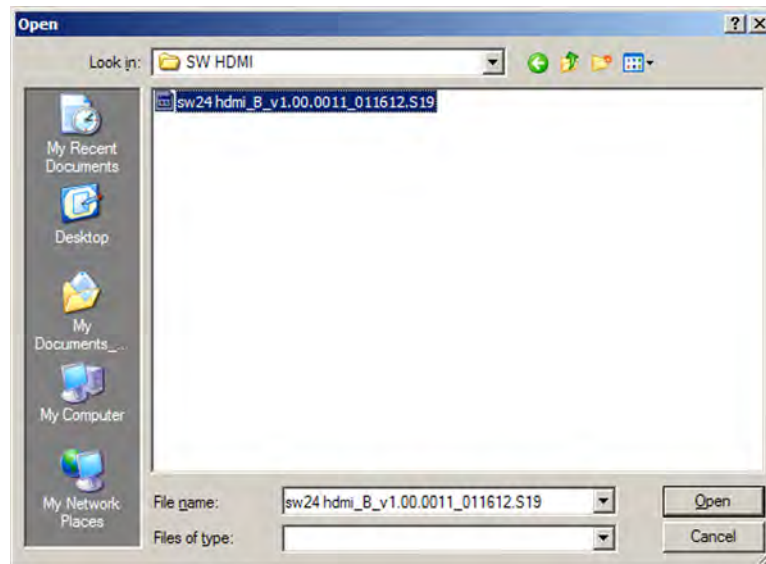

Figure 23. Open Window for Firmware File Selection

ATTENTION: Valid firmware files must have the file extension **S19**. A file with any other extension is not a firmware upgrade for this product and could cause the switcher to stop functioning.

NOTE: The original factory-installed firmware is permanently available on the SW HDMI. If the attempted firmware upload fails for any reason, the switcher reverts to the factory version.

On the Add Device window, the path to the new firmware file is displayed in the **Path** field.

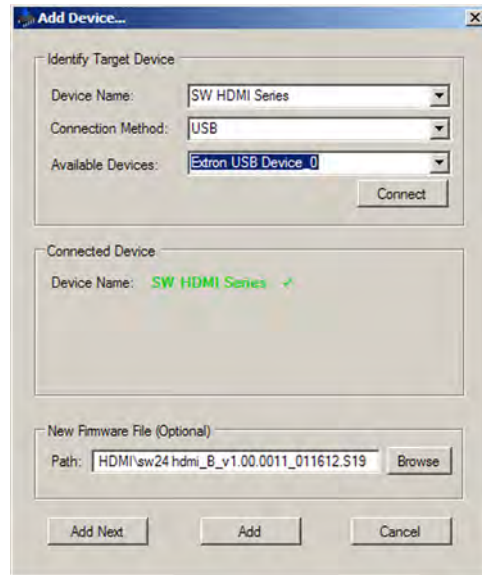

Figure 24. Path to the New Firmware File on the Add Device Window

- 11.** If this is the only device to which you are uploading firmware, click **Add**. The switcher information is added to the Device section of the Firmware Loader window and the Add Device window closes.

If you will be uploading the firmware to multiple SW HDMI switchers that are connected to your computer, do the following:

- a.** Click **Add Next**. Your first device is added to the Device section of Firmware Loader window, and the Add Device window remains open.
- b.** For each additional device you want to add to the Firmware Loader window, repeat steps 5 through 10, then click **Add Next**.
- c.** For the **last** device, click **Add** (instead of **Add Next**) to add the device and to close the Add Device window.

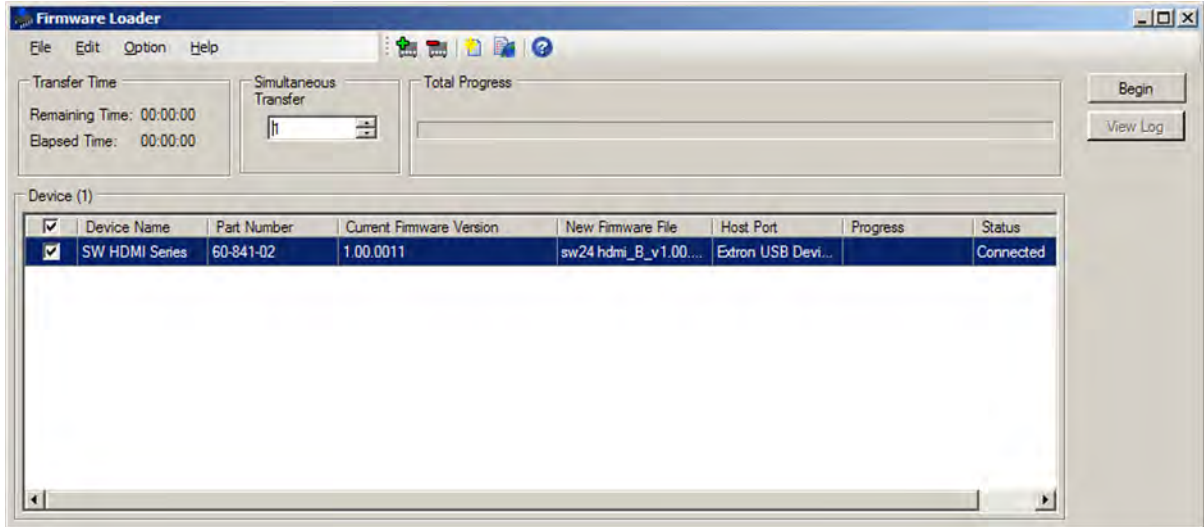

Figure 25. Firmware Loader Screen with an SW HDMI Added

12. If you want to remove a device from the Device section, do the following:

- a. Click on the names of the devices to be deleted, to highlight them.
- b. Select **Remove Selected Device(s)** from the **Edit** menu.
- c. On the Remove Device(s) window, select or deselect any devices on the list as desired, then click **Remove**.

To remove **all** devices, select **Remove All Devices** from the **Edit** menu.

13. Click **Begin**. The following indicators show the progress of the update:

- The Transfer Time section shows the remaining and elapsed time for the update.
- The Total Progress section displays a progress bar with **Uploading...** above it.
- In the Device section, the **Progress** column displays an incrementing percentage and another progress bar. The **Status** column displays **Uploading**.

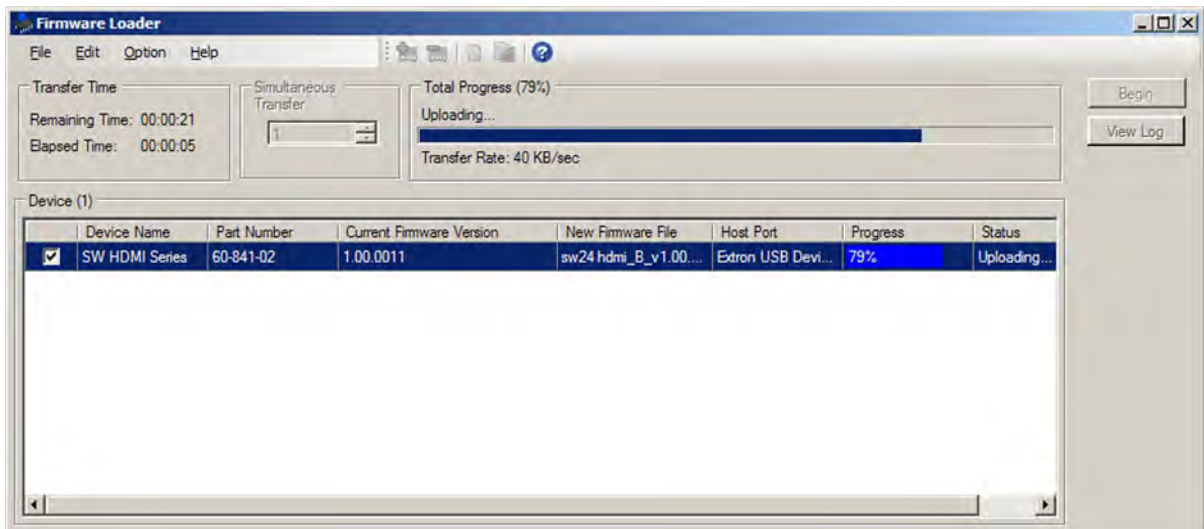

Figure 26. Firmware Upload in Progress

14. The upload is complete when the **Remaining Time** field shows **00.00.00**, the **Progress** column shows **100%**, and **Completed** is displayed above the progress bar and in the **Status** column. Close the Firmware Loader window.

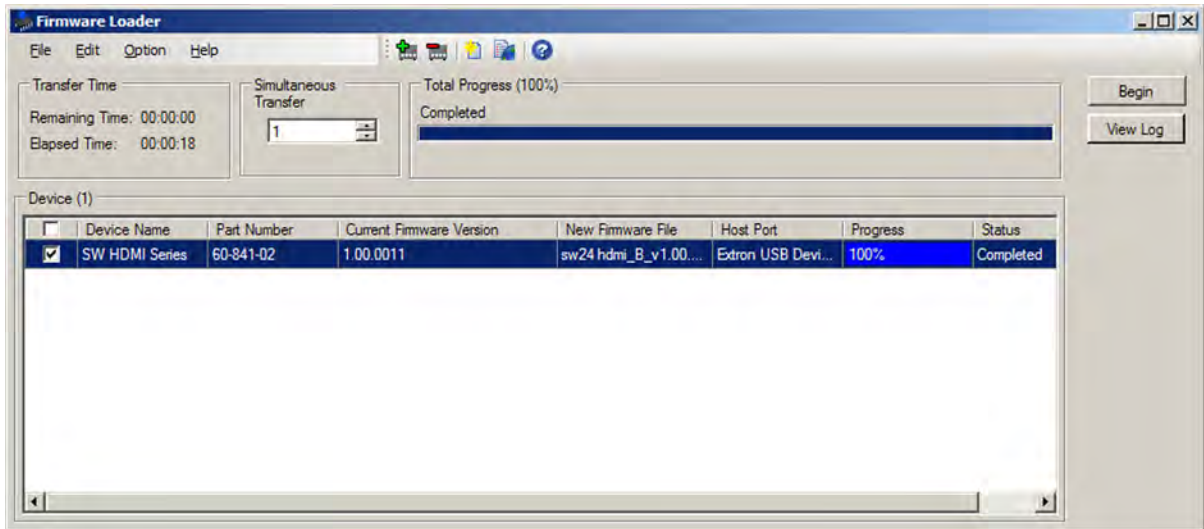

Figure 27. Firmware Upload Complete

Reference Information

Mounting the SW HDMI

The SW HDMI switcher can be set on a table, mounted on a rack shelf, or mounted under a desk, podium, or table.

Tabletop Use

Four self-adhesive rubber feet are included with the SW HDMI. For tabletop use, attach one foot at each corner on the bottom of the unit, and place the switcher where desired.

Rack Mounting

The SW2 and SW4 HDMI models can be mounted on a 9.5-inch, 6-inch, or 3.5-inch deep rack shelf. They can also be mounted vertically to the front or back rack support. The SW6 and SW8 HDMI models can be mounted directly to the rack using the provided mounting brackets. For mounting procedures, see the instructions provided with the mounting option.

UL rack mounting guidelines

The following Underwriters Laboratories (UL) guidelines pertain to the safe installation of the equipment in a rack.

- 1. Elevated operating ambient temperature** — If the equipment is installed in a closed or multi-unit rack assembly, the operating ambient temperature of the rack environment may be greater than room ambient temperature. Therefore, install the equipment in an environment compatible with the maximum ambient temperature (TMA = +122 °F, +50 °C) specified by Extron.
- 2. Reduced air flow** — Install the equipment in a rack so that the amount of air flow required for safe operation of the equipment is not compromised.
- 3. Mechanical loading** — When mounting the equipment in the rack, ensure that uneven mechanical loading does not cause a hazardous condition.
- 4. Circuit overloading** — When connecting the equipment to the supply circuit, consider the effect that circuit overloading might have on overcurrent protection and supply wiring. Consider equipment nameplate ratings when addressing this concern.
- 5. Reliable earthing (grounding)** — Maintain reliable grounding of rack-mounted equipment. Pay particular attention to supply connections other than direct connections to the branch circuit (for example, use of power strips).

Furniture Mounting—SW2 and SW4 HDMI Only

The SW2 and SW4 HDMI switchers can be mounted under a desk, table, or podium using an under-desk mounting kit (see the mounting instructions provided with the kit).

Extron Warranty

Extron Electronics warrants this product against defects in materials and workmanship for a period of three years from the date of purchase. In the event of malfunction during the warranty period attributable directly to faulty workmanship and/or materials, Extron Electronics will, at its option, repair or replace said products or components, to whatever extent it shall deem necessary to restore said product to proper operating condition, provided that it is returned within the warranty period, with proof of purchase and description of malfunction to:

**USA, Canada, South America,
and Central America:**

Extron Electronics
1230 South Lewis Street
Anaheim, CA 92805
U.S.A.

Japan:

Extron Electronics, Japan
Kyodo Building, 16 Ichibancho
Chiyoda-ku, Tokyo 102-0082
Japan

Europe and Africa:

Extron Europe
Hanzeboulevard 10
3825 PH Amersfoort
The Netherlands

China:

Extron China
686 Ronghua Road
Songjiang District
Shanghai 201611
China

Asia:

Extron Asia Pte Ltd
135 Joo Seng Road, #04-01
PM Industrial Bldg.
Singapore 368363
Singapore

Middle East:

Extron Middle East
Dubai Airport Free Zone
F12, PO Box 293666
United Arab Emirates, Dubai

This Limited Warranty does not apply if the fault has been caused by misuse, improper handling care, electrical or mechanical abuse, abnormal operating conditions, or if modifications were made to the product that were not authorized by Extron.

NOTE: If a product is defective, please call Extron and ask for an Application Engineer to receive an RA (Return Authorization) number. This will begin the repair process.

USA: 714.491.1500 or 800.633.9876
Asia: 65.6383.4400

Europe: 31.33.453.4040
Japan: 81.3.3511.7655

Units must be returned insured, with shipping charges prepaid. If not insured, you assume the risk of loss or damage during shipment. Returned units must include the serial number and a description of the problem, as well as the name of the person to contact in case there are any questions.

Extron Electronics makes no further warranties either expressed or implied with respect to the product and its quality, performance, merchantability, or fitness for any particular use. In no event will Extron Electronics be liable for direct, indirect, or consequential damages resulting from any defect in this product even if Extron Electronics has been advised of such damage.

Please note that laws vary from state to state and country to country, and that some provisions of this warranty may not apply to you.

Extron Headquarters +1.800.633.9876 (Inside USA/Canada Only) Extron USA - West +1.714.491.1500 +1.714.491.1517 FAX	Extron Europe +800.3987.6673 (Inside Europe Only) Extron USA - East +1.919.850.1000 +1.919.850.1001 FAX	Extron Asia +65.6383.4400 +65.6383.4664 FAX	Extron Japan +81.3.3511.7655 +81.3.3511.7656 FAX	Extron China +86.21.3760.1568 +86.21.3760.1566 FAX	Extron Middle East +971.4.299.1800 +971.4.299.1880 FAX	Extron Korea +82.2.3444.1571 +82.2.3444.1575 FAX	Extron India 1800.3070.3777 (Inside India Only) +91.80.3055.3777 +91.80.3055.3737 FAX
---	---	--	---	---	---	---	--